

NEW HOLLAND

E9SR

NEW HOLLAND KOBELCO



RESPECT FOR THE ENVIRONMENT

The excavator respects the European "reduced noise level" as per directive 2000/14/EC phase 2.

NET FLYWHEEL POWER	6 kW - 8 hp
OPERATING WEIGHT	1 060 kg
REAR END SWING RADIUS	490 mm
BUCKET CAPACITY	0.012 - 0.020 m ³

A product of the global alliance between CNH and KOBELCO

CNH NEW HOLLAND IS A BRAND OF CNH. CNH: THE TOTAL SOLUTIONS CHOICE FOR YOUR SPECIFIC BUSINESS NEEDS.

 **NEW HOLLAND**

PROVEN PERFORMANCE

SPECIFICATIONS

MAIN FEATURES

Net flywheel power (ISO14396)	6.0 kW/8.0 hp
Operating weight	1060 kg
Maximum digging depth	1750 mm
Breakout force: bucket	10.8 kN
dipper stick	6.2 kN
Transport length	2870 mm
Transport width	750 mm
Transport height:	
with roll bar lifted	2470 mm
with roll bar retracted	1700 mm

ENGINE

Make	YANMAR
Model	2TNE68-YB
Type	4-stroke diesel
Number of cylinders	2
Displacement	0.522 litri
Aspiration	natural
Rated speed	2000 rpm

ELECTRICAL SYSTEM

Voltage	12 V
---------	------

HYDRAULIC SYSTEM

T.F.S. Total Flow hydraulic System with two axial piston variable displacement pumps for completely fully simultaneous unit movements, including blade and slewing.

The two variable delivery pumps ensure full use of all installed hydraulic power in individual and combined movements. Piloted controls:

Main hydraulic pumps	axial piston variable displacement
Total delivery	2 x 11 l/min
Maximum operating pressure	206 bar
Piloting circuit pump	gear type

SWING

Hydraulic motor	axial piston type
Swing speed	9 rpm
Swing brake	manually operated
Boom slewing angle:	
- left	80 °
- right	50 °

Minimum 490 mm rear end swing radius to ensure superstructure remains within track overall dimensions. Can operate in cramped areas in total safety.

1545 mm overall dimensions with 180° slewing radius.

UNDERCARRIAGE

Hydraulic control variable track gauge.	
Total track width:	
tracks retracted	750 mm
tracks extended	980 mm
Gauge	1010 mm
Lower rollers	3
Travel speeds	2
Travel speed range	2.0/4.0 km/h
Maximum continuous slope	58% (30°)

BLADE

Width x Height	750/980 x 200 mm
Blade lift	190 mm
Blade lower	270 mm

CAPACITIES

Fuel	9.0 litres
Hydraulic system	10.0 litres

DIMENSIONS (mm)

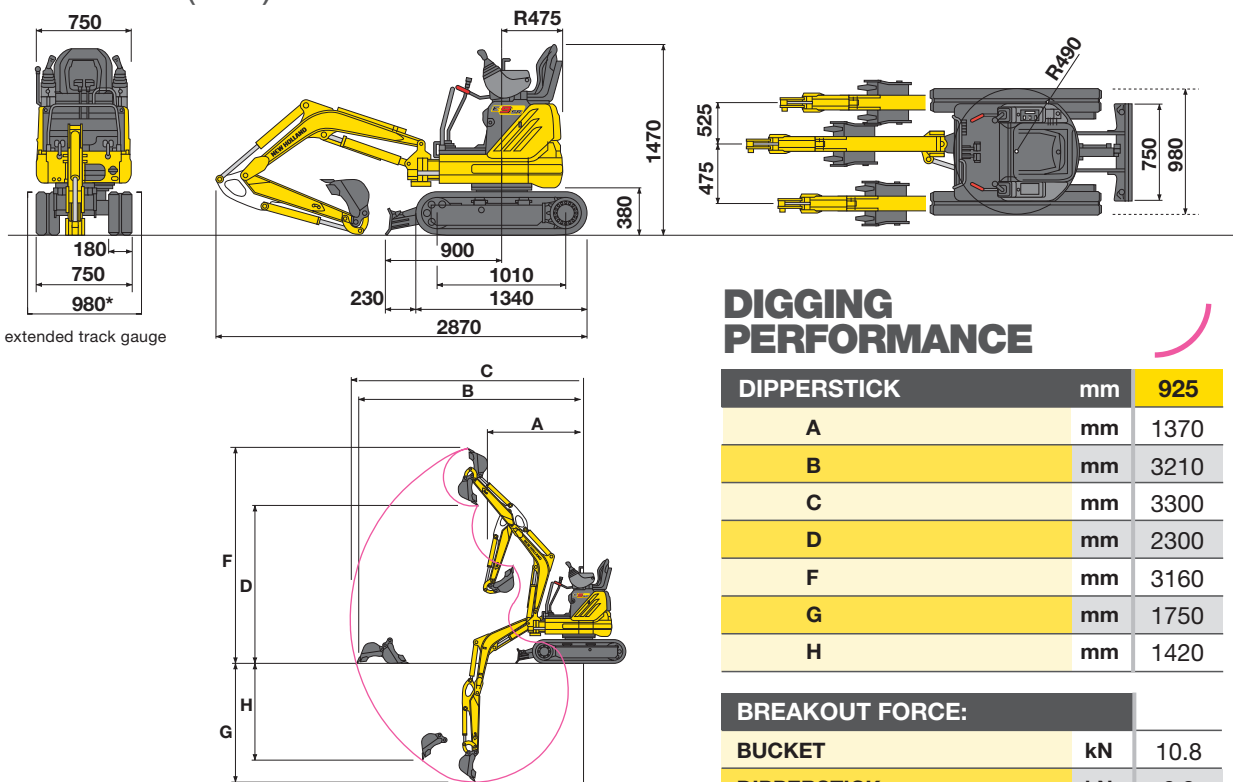

DIGGING PERFORMANCE

DIPPERSTICK	mm	925
A	mm	1370
B	mm	3210
C	mm	3300
D	mm	2300
F	mm	3160
G	mm	1750
H	mm	1420

BREAKOUT FORCE:

BUCKET	kN	10.8
DIPPERSTICK	kN	6.2

The information contained in this brochure is intended to be a general nature only. The NEW HOLLAND KOBELCO CONSTRUCTION MACHINERY S.p.A. company may at any time and from time to time, for technical or other necessary reasons, modify any of the details or specifications of the product described in this brochure. Illustrations do not necessarily show products in standard conditions. The dimensions, weights and capacities shown herein, as well as any conversion data used, are approximate only and are subject to variations within normal manufacturing techniques.