

KOMATSU

Utility

PC
09-1



PC09-1

PC09-1

MINI EXCAVATOR

NET POWER
SAE J1349
6,3 kW - 8,5 HP
OPERATING WEIGHT
From 880 kg
to 980 kg

PC09-1 MINI EXCAVATOR

Fruit of KOMATSU technology and experience, the new PC09-1 miniexcavator supplies the right power and digging force while operating in restricted areas.

In between adjacent walls, inside buildings, or inside tunnels bigger machines could be too large or heavy. Moreover, the new PC09-1 is particularly apt to work in gardening, small renovations or demolitions, or in drainage system jobs.

Sturdiness and excellent stability guarantee safety in any work situation.

Thanks to the typical tubular shape of the arm, the mono-block frame and the metallic hood the machine can be used under the most severe working conditions with no problem.

Compactness

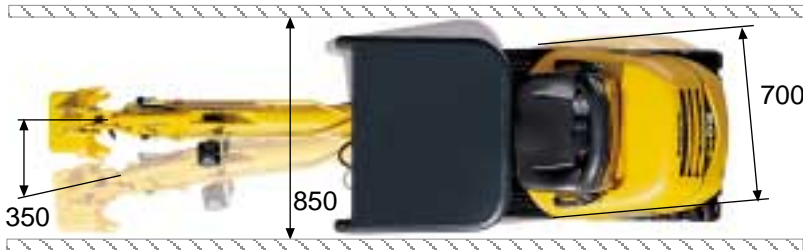

New Controls



Easy Maintenance



Great Stability

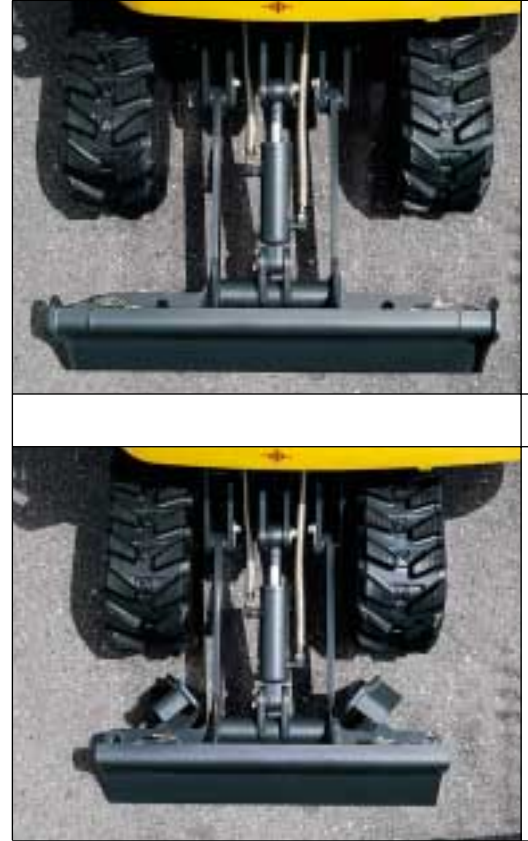

- Two travelling speeds
- Hydraulic variable gauge
- Arm with integrated demolition breaker (option)
- Fully opening engine bonnet
- Water cooled green engine
- Self lubricating bushes in boom and arm
- Ready to operate in wide range of applications
- Pipes located inside the boom.
- Boom off-set 90°/50°
- Compact dimensions
- Low ground bearing
- Easy to operate
- Easy to transport
- Fast and powerful

TECHNICAL SPECIFICATIONS



ENGINE

Model Komatsu 2D68E-3A
 Type Low emissions 4-cycle diesel engine
 Displacement 522 cm³
 Rated power:
 (SAE J 1349) 6,3 kW / 8,5 HP - 2.200 rpm
 Cooling system water



OPERATING WEIGHT

Operational mass with standard bucket, fully serviced + 80 kg operator (ISO 6016).
 Operating weight with rubber shoes 880 (980) kg
 TOPS canopy +100 kg (optional)



HYDRAULIC SYSTEM

Main pumps 2 x gear pump
 Max delivery 11 + 11 l/min
 Max operating pressure 16 MPa (160 bar)
 Max breakout force 1.130 daN - (1.075 kg)



UNDERCARRIAGE

Width x blade height 700 x 200 mm
 Shoes width 180 mm
 Ground pressure (std. version) 0,25 kg/cm²
 Hydraulically operated track extension



TRANSMISSION

Type Hydrostatic transmission, controlled and steered by means of two levers
 Max traction force 1.160 daN - (1.090 kg)
 Travel speed 1,5 - 3 km/h



REFILLS

Fuel tank 10,8 l
 Engine oil 1,9 l
 Hydraulic oil tank 16,4 l



HAMMER

Impact energy 108 J - (11 kgm)
 Blow Frequency 800 b.p.m

DIMENSIONS

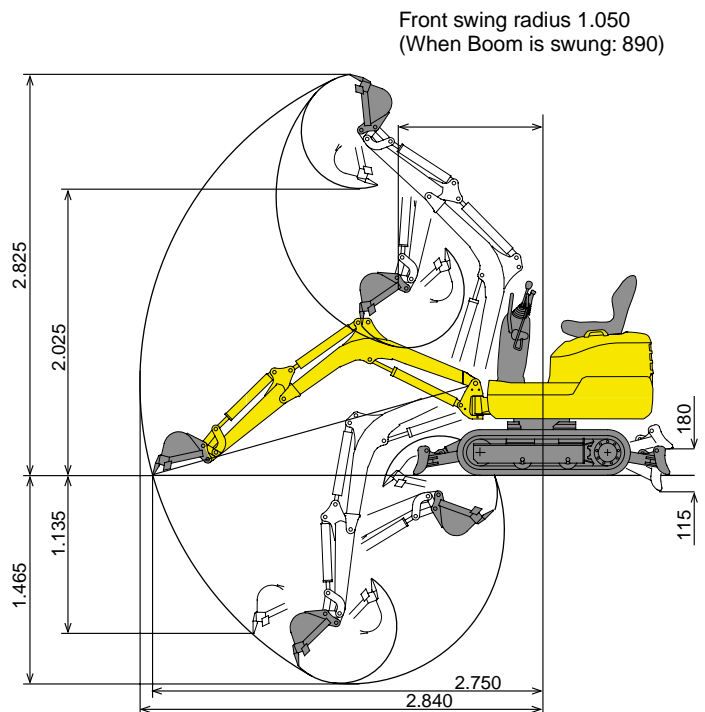
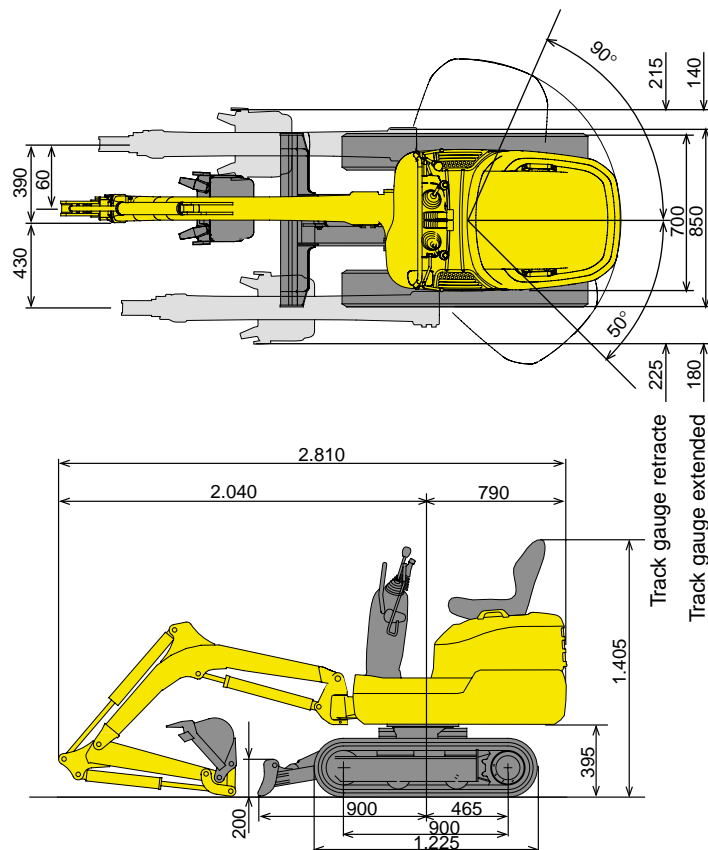

PC09-1 MINI EXCAVATOR

STANDARD EQUIPMENT

- | | | |
|--|---|---|
| <ul style="list-style-type: none"> • Two travelling speeds • Hydraulic variable gauge • Front blade | <ul style="list-style-type: none"> • ORFS connections • One piece cast iron frame and metallic hood | <ul style="list-style-type: none"> • Safety lock lever |
|--|---|---|

OPTIONAL EQUIPMENT

- | | | |
|---|---|--|
| <ul style="list-style-type: none"> • Arm with demolition breaker | <ul style="list-style-type: none"> • TOPS canopy | <ul style="list-style-type: none"> • Bucket range |
|---|---|--|

KOMATSU

Komatsu Utility Europe
 Head Office
 via Atheste 4
 35042 Este (Padova) Italy
 Tel. +39 0429 616111
 Fax +39 0429 601000
www.equipmentcentral.com
utility@komatsu.it



COMPANY WITH
 ENVIRONMENTAL MANAGEMENT
 SYSTEM CERTIFIED BY DNV
ISO 14001