

# MANISCOPIC

**MT 1440**  
SLT MU ORH  
U ORH RC



- Working height : 15.44 m
- Maximum forward reach : 12 m
- Standard capacity : 365 kg including 3 people
- HYDRAULIC STABILIZERS and FRAME LEVELLING
- Extendable platform from 2.25 m to 4 m adjustable (180°).

 **MANITOU**

# MT 1440 SLT MU ORH/U ORH RC

 **Capacity** : .....365 kg including 3 people  
 Working height : .....15.44 m  
 Basket floor height : .....13.44 m

 **Lifting** :  
 Times : unladen / loaded (in s)  
 Lifting .....11.9/12.4  
 Lowering .....8.2/7.7  
 Simultaneous extension 1st and 2nd booms...17.4/18.3  
 Simultaneous retraction 1st and 2nd booms...15/14.5

 **Tyres**  
 15.5/80-24

 **Equipment** :  
 Forks (mm)  
 length .....1200  
 Width x thickness .....125 x 50  
 Extendable platform from 2,25 to 4 m adjustable 180°

 **Multidisc brakes - hydraulically assisted on both axles**

 **PERKINS Engine**  
 Type.....1104C.44 Turbo  
 Capacity .....4 cyl. - 4400 cm<sup>3</sup>  
 Power .....100 HP/74,5 kw  
 (ISO/TR 14396) at 2200 rpm  
 Maximum torque : .....412 Nm at 1400 rpm  
 Direct Injection  
 Water Cooling

 **Transmission** .....Torque convertor  
 Electro-hydraulic reversing shift  
 4 speeds forward and reverse  
 Maximum travel speed .....25 km/h

 **Hydraulics**  
 Lifting/tilting pump  
 gear type: .....260 bars/163 l/mn  
 Flow divider with priority to steering and brakes

 **Capacities**  
 Cooling system .....18.5 l.  
 Engine oil : .....11 l.  
 Hydraulic oil .....126 l.  
 Transmission oil .....15.1 l.  
 Fuel tank .....135 l.

 **Weight unladen** (with platform) .....11770 kg  
**Overall width** .....2.40 m  
**Overall height** .....2.60 m  
**Turning radius** (outside wheels) .....4.16 m  
**Overall length** .....8.09 m  
**Ground clearance** .....0.48 m  
**Drawbar pull** .....10090 daN

This equipment described in this leaflet may be standard, optional, or unavailable, depending on the versions.  
 For more details, contact your MANITOU dealer.

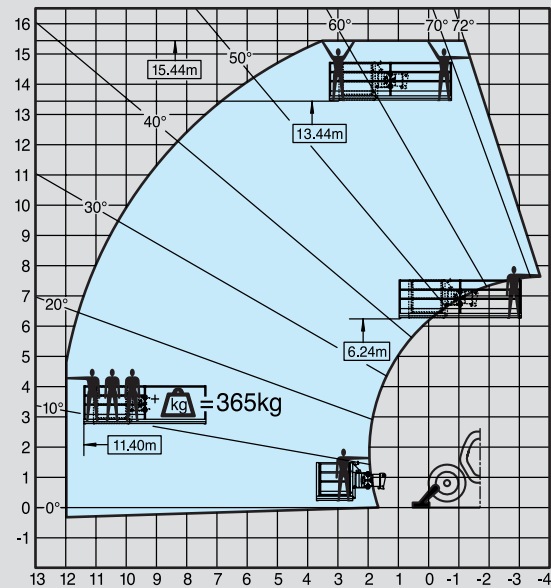

4M PLATFORM WITH HYDRAULIC ROTATION

Options of platform	
Fixed 2 m	365 kg including 3 people
Adjustable 2 m	
Adjustable 2.40 m	
Adjustable and extendable 2.45/5 m	
Adjustable and extendable 2.45/6 m	1000 kg including 3 people
Adjustable and extendable 2.25/4 m	
Roofer Platform	1000 kg including 3 people

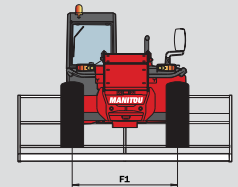
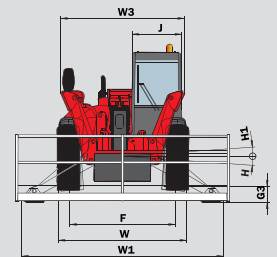

A	1200
B	2770
C	4270
C1	2348
C2	887
D1	6168
D2	4405
E	8090
F	1990
F1	1990
G	480
G1	475
G2	480
G3	290
H	7°
H1	7°
I	1050
J	950
K	2250-4000
L	1250
N	1890/1940
P2	45,5°
P3	50°
R	3950
S	9812
T	5916
U1	2605
U2	2785
V	7386
V1	1470
V2	4157
W	2405
W1	3820
W2	1050
W3	2350
Y	90°
Z	90°

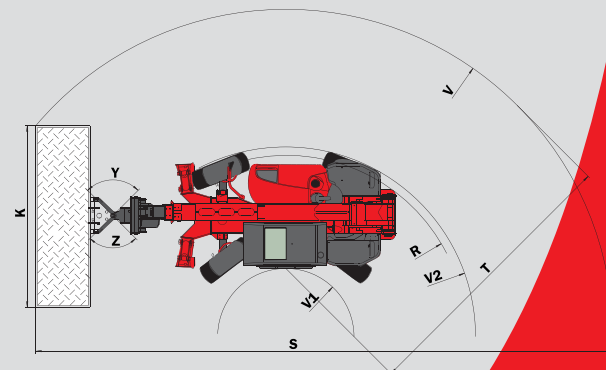
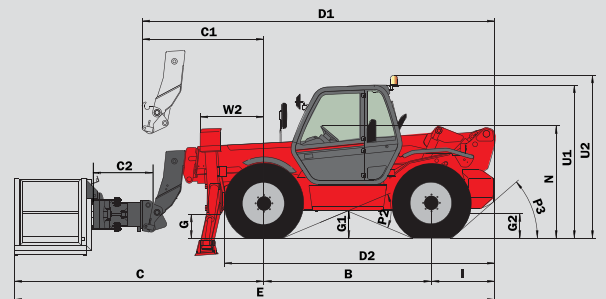

mm

